



Instruction Sheet

102-232

0010-IFC 3 Speed Cartridge Circulator “Service Pump” with Integral Flow Check and 4-Bolt Universal Flange

SUPERSEDES: New

EFFECTIVE: April 1, 2007

Plant ID# 001-3904

APPLICATION:

Use the “Service Pump” to replace most commonly used circulators.

- Maximum operating pressure is 125 psi (862 kPa).
- Maximum water temperature not to exceed nameplate rating.
- Cast iron circulators are to be used for closed loop systems only.
- Taco Cartridge circulator pumps are for indoor use only – employer uniquement a l’interieur

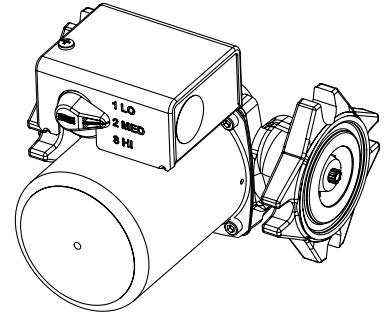

WARNING: Do not use in swimming pool or spa areas; pump has not been investigated for this application.

WARNING: In the event the retaining screws have been pulled out of the housing, DO NOT replace them. Use of any other screw may short out the stator windings, creating a risk of electrical shock.

CAUTION: When installing electrical connections, do not apply mechanical loads to the capacitor box; otherwise, retaining screws may be pulled out of the housing, making circulator unusable.

CAUTION: 1. The addition of petroleum based fluids or certain chemical additives to systems utilizing TACO equipment voids the warranty.

2. Use supply wires suitable for 90°C – ATTENTION: Employer des fils d’alimentation adequats pour 90°C.

WARNING: To avoid electrical shock, disconnect the power supply to the circulator and the main electrical unit.

INSTALLATION:

1. Location – Install the “OO” circulator on the supply side of the boiler “pumping away” from the expansion tank as shown in Figure 1. This is the best pump location for optimum system performance and maintaining positive system pressure. An alternate location is on the boiler return line as shown in Figure 2.
2. Mounting position – Mount circulator with the motor in the horizontal position. It may be mounted vertically with the motor up, provided that the system cold fill pressure is at least 20 psi (138 kPa) to ensure proper air purging and prevent flashing.
3. Rotating body – Body has an arrow on the front that indicates direction of flow. To rotate body, remove the four body bolts, rotate body and replace bolts. Make sure that the junction box is NOT located underneath the circulator. (The junction box must NOT be located in the 6 o’clock position, as viewed from the motor end.)
4. Electrical connections – Observe all applicable codes when connecting to power supply. The motor is thermally protected, and does not require additional overload protection. Either colored wire from the capacitor box can be attached to either colored wire from the power supply. There is no “hot” or “common” wire leading from the capacitor box. Typical installation would be to attach the white wire to the white (common) power supply wire and either the yellow or blue wire to the black (hot) power supply wire. The pump cannot run backwards.

ELECTRICAL DATA

SPEED	Amps (Watts)
1	0.75 (85)
2	0.91 (100)
3	1.10 (125)

CAUTION: Installations at higher elevations over 5000 feet must have higher fill pressure of 20psi minimum to prevent pump cavitation and flashing. Premature failure may result. Adjust expansion tank pressure to equal fill pressure. A larger size expansion tank may be required.

5. Fill system with tap water – The system must be filled before operating the circulator. The bearings are water lubricated and should not be allowed to operate dry. Filling the system will result in immediate lubrication of the bearings. It is always good practice to flush a new system of foreign matter before starting the circulator.
6. Circulator operation – Operate the circulator for 5 minutes immediately after flushing the system to purge remaining air from the bearing chamber. This is especially important when installing the circulator during the off-season.
7. Turn speed dial on circulator to the desired speed and performance range. See Figure 3.

FIGURE 1:

PREFERRED PIPING FOR CIRCULATORS ON BOILER SUPPLY LINE

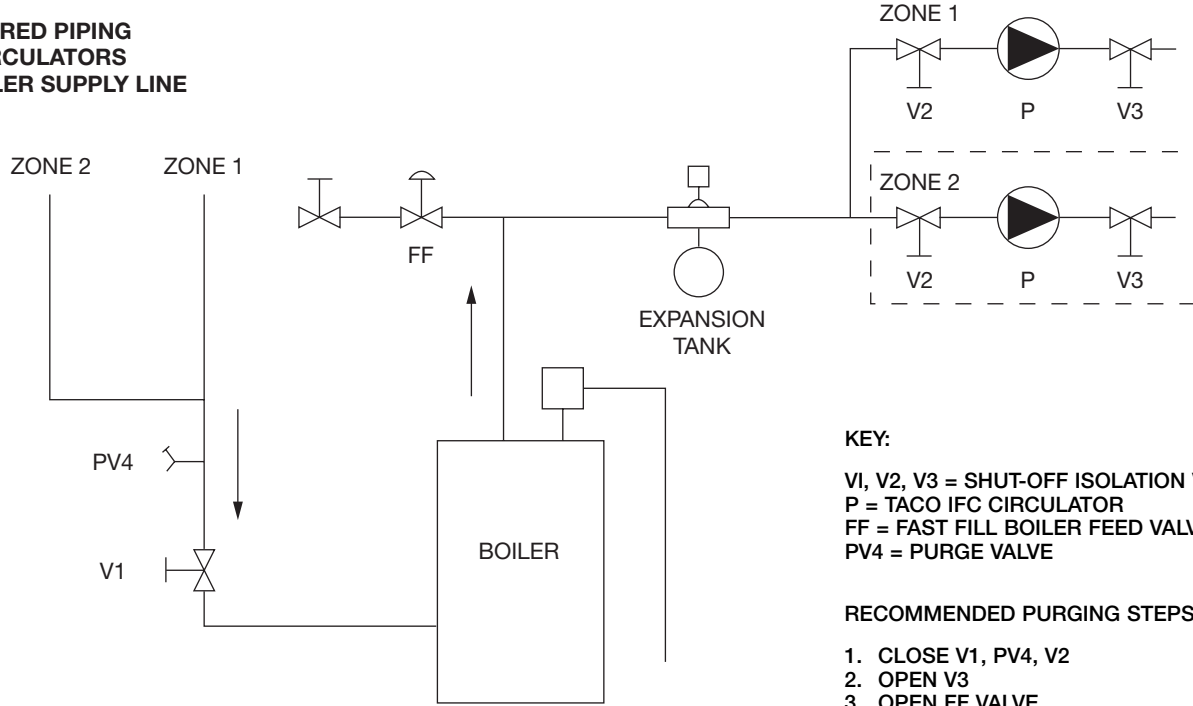

KEY:

V1, V2, V3 = SHUT-OFF ISOLATION VALVE
 P = TACO IFC CIRCULATOR
 FF = FAST FILL BOILER FEED VALVE
 PV4 = PURGE VALVE

RECOMMENDED PURGING STEPS:

1. CLOSE V1, PV4, V2
2. OPEN V3
3. OPEN FF VALVE
4. OPEN V2, PV4, TO PURGE ZONE 1
5. CLOSE FF VALVE
6. CLOSE V2, PV4
7. REPEAT STEPS 1 TO 6 FOR EACH ADDITIONAL ZONE
8. OPEN V1 WHEN ALL ZONES ARE PURGED
9. ADJUST SYSTEM TO DESIRED OPERATING FILL PRESSURE IF REQUIRED

FIGURE 2:

ALTERNATE PIPING FOR CIRCULATORS ON BOILER RETURN LINE

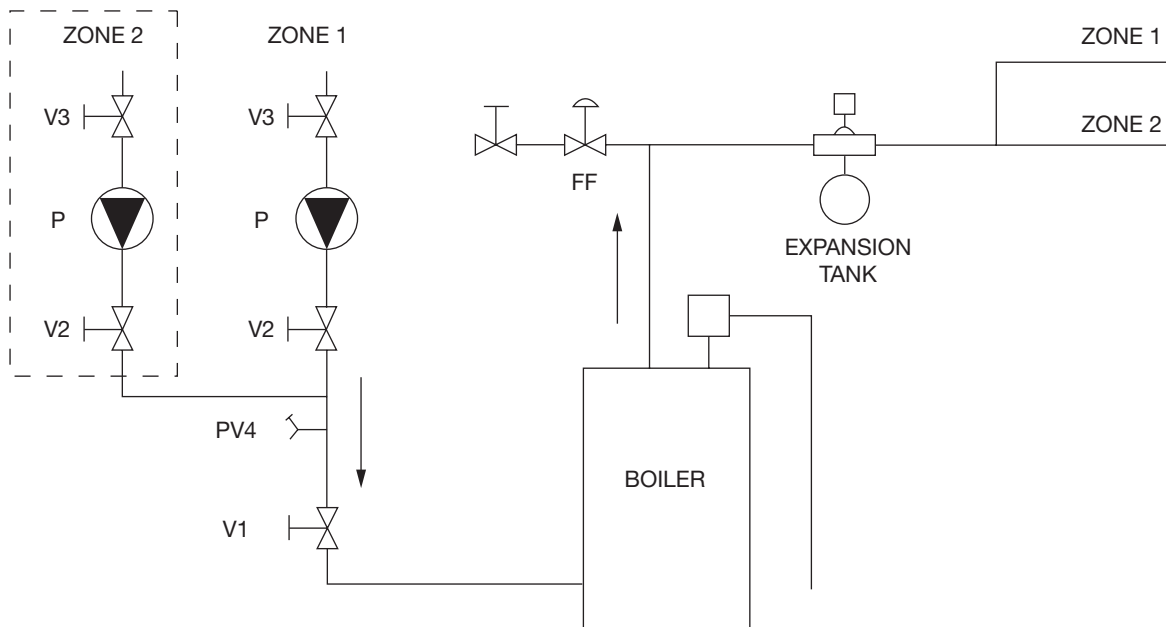

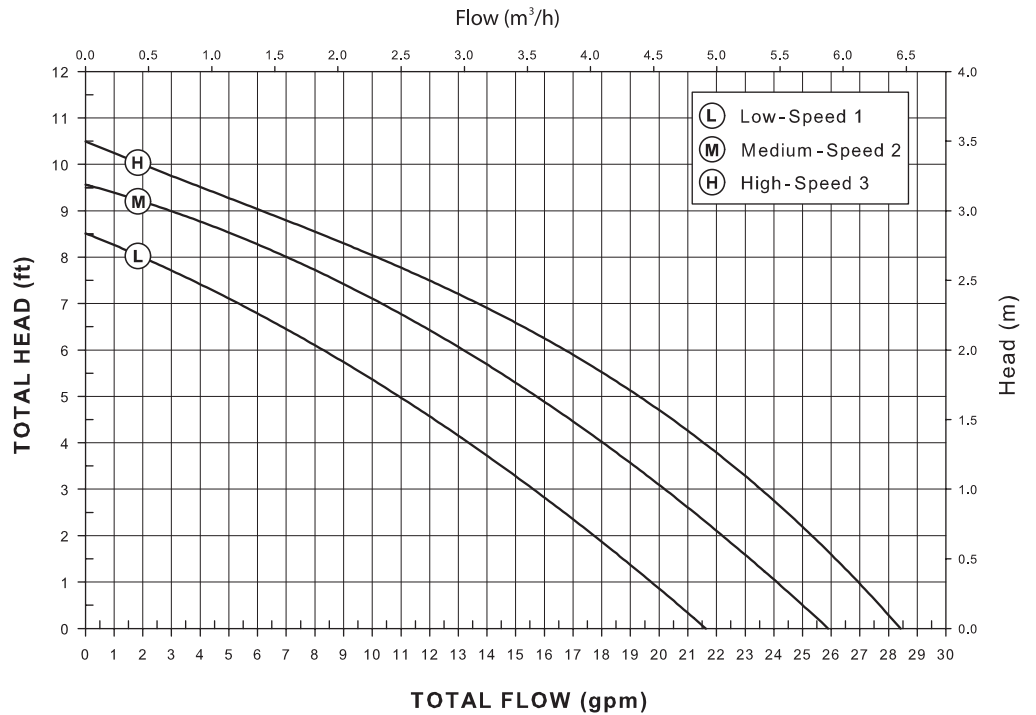
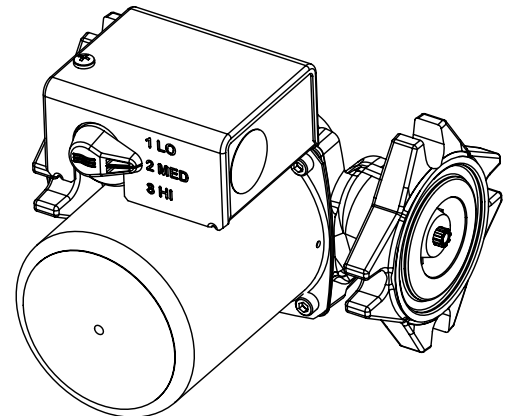

Figure 3: Multi-Speed Control Dial

PUMP REPLACEMENT CROSS REFERENCE

Multi-Speed		Single Speed Models		
TACO		Armstrong	B & G	TACO
0010-MSF1-IFC Service Pump	Speed 1	Astro-20	NRF-9F/LW	005, 005-IFC
	Speed 2	-	LRF-20BF	007, 007-IFC
	Speed 3	S-25	100, NRF-22/33	110, 0010, 0010-IFC



PROPER REMOVAL/REPLACEMENT OF THE INTEGRAL FLOW CHECK (IFC)

Your “00” circulator with an Integral Flow Check (IFC) is designed for easy removal, service and replacement. Please follow these instructions to ensure proper service and operation of the circulator.

REMOVAL:

1. Disconnect power to circulator and related equipment.
2. Shut off water supply. Isolate circulator using service valves or drain system if valves are not available.
3. Allow system to cool to prevent scalding. Loosen flange bolts slowly to relieve system pressure and remove circulator from the system. Access the IFC located in the discharge flange (Figure 4).
4. Using needle nose pliers, carefully grip the IFC body and remove slowly.

Figure 4: View of IFC in discharge flange of “00” pump casing.

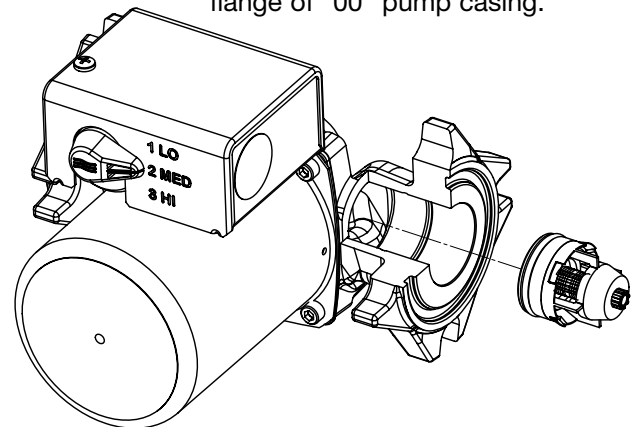

REPLACEMENT:

1. Make sure the IFC pocket is clean and free of any debris.
2. Position IFC into the machined pocket inside the casing as shown in Figure 4. Firmly press the IFC into the pocket until it snaps into place.
3. Reinstall circulator with new flange gaskets, if required.
4. Open water supply and refill system. Check for any leaks.
5. Reconnect power to circulator and check for proper operation of system.

REPLACING MOTOR ASSEMBLY:

1. Disconnect the electrical supply.
2. Reduce system pressure to 0 psi and allow system to return to room temperature. Isolate the circulator by closing the service valves or draining the system.
3. Remove the body bolts and swing motor assembly away from the body.
4. Transfer impeller cartridge from old motor to new motor making sure the cover plate is between the cartridge flange and motor housing.
5. Install new motor, and reassemble circulator using the new gasket and bolts supplied.
6. Follow the "installation" procedure to start up the circulator

REPLACING CARTRIDGE ASSEMBLY:

1. Disconnect the electrical supply.
2. Reduce system pressure to 0 psi and allow system to return to room temperature. Isolate the circulator by closing the service valves or draining the system.
3. Remove the body bolts and swing motor assembly away from the body.
4. Pull cartridge out of the motor housing.
5. Install replacement cartridge, making sure that the cover plate is between the cartridge flange and motor.
6. Make sure the replacement cartridge corresponds to the full circulator product number. A complete parts list is available from your local plumbing supply wholesaler.
7. Reassemble the circulator using the new gasket and bolts supplied.
8. Follow the "Installation" procedure to start up the circulator.

REPLACING CAPACITOR:

1. Replacement capacitor must have same rating as originally furnished.

LIMITED WARRANTY STATEMENT

Taco, Inc. will repair or replace without charge (at the company's option) any product or part which is proven defective under normal use within one (1) year from the date of start-up or one (1) year and six (6) months from date of shipment (whichever occurs first).

Taco, Inc. will repair or replace without charge (at the company's option) any Taco 00 Series circulator cartridge that is proven defective under normal use within three (3) years from the date of start-up or three (3) years and six (6) months from date of shipment (whichever occurs first).

In order to obtain service under this warranty, it is the responsibility of the purchaser to promptly notify the local Taco stocking distributor or Taco in writing and promptly deliver the subject product or part, delivery prepaid, to the stocking distributor. For assistance on warranty returns, the purchaser may either contact the local Taco stocking distributor or Taco. If the subject product or part contains no defect as covered in this warranty, the purchaser will be billed for parts

and labor charges in effect at time of factory examination and repair.

Any Taco product or part not installed or operated in conformity with Taco instructions or which has been subject to misuse, misapplication, the addition of petroleum-based fluids or certain chemical additives to the systems, or other abuse, will not be covered by this warranty.

If in doubt as to whether a particular substance is suitable for use with a Taco product or part, or for any application restrictions, consult the applicable Taco instruction sheets or contact Taco at [401-942-8000].

Taco reserves the right to provide replacement products and parts which are substantially similar in design and functionally equivalent to the defective product or part. Taco reserves the right to make changes in details of design, construction, or arrangement of materials of its products without notification.

TACO OFFERS THIS WARRANTY IN LIEU OF ALL OTHER EXPRESS WARRANTIES. ANY

WARRANTY IMPLIED BY LAW INCLUDING WARRANTIES OF MERCHANTABILITY OR FITNESS IS IN EFFECT ONLY FOR THE DURATION OF THE EXPRESS WARRANTY SET FORTH IN THE FIRST PARAGRAPH ABOVE.

THE ABOVE WARRANTIES ARE IN LIEU OF ALL OTHER WARRANTIES, EXPRESS OR STATUTORY, OR ANY OTHER WARRANTY OBLIGATION ON THE PART OF TACO.

TACO WILL NOT BE LIABLE FOR ANY SPECIAL, INCIDENTAL, INDIRECT OR CONSEQUENTIAL DAMAGES RESULTING FROM THE USE OF ITS PRODUCTS OR ANY INCIDENTAL COSTS OF REMOVING OR REPLACING DEFECTIVE PRODUCTS.

This warranty gives the purchaser specific rights, and the purchaser may have other rights which vary from state to state. Some states do not allow limitations on how long an implied warranty lasts or on the exclusion of incidental or consequential damages, so these limitations or exclusions may not apply to you.

SYSTEMS MADE EASY

TACO, INC., 1160 Cranston Street, Cranston, RI 02920 Telephone: (401) 942-8000 FAX: (401) 942-2360.
TACO (Canada), Ltd., 6180 Ordan Drive, Mississauga, Ontario L5T 2B3. Telephone: 905/564-9422. FAX: 905/564-9436.

Visit our web site at: <http://www.taco-hvac.com>

Printed in USA
Copyright 2007
TACO, Inc.