



# Submittal Data Information

## FloodBreaker® Whole House Water Shut Off

101-161

Effective: December 10, 2014

Supersedes: June 1, 2013

Job: \_\_\_\_\_ Engineer: \_\_\_\_\_ Contractor: \_\_\_\_\_ Rep: \_\_\_\_\_

ITEM NO.	MODEL NO.	

### Features

- Programmable Leak Detection Settings
- Programmable Vacation Mode Leak Settings
- Audible Alarm
- Floor Sensor
- Output Contact
- Input Contact
- Operates on Batteries and 9V DC Power Supply
- Reduces Property Damage
- Push Button Reset
- Mounts in Horizontal or Vertical Pipe

### Performance

- Max. Flow: 15.5 gpm (58.7 L/Min)  
*Caution: Flow should never exceed standards for pipe size.*
- Max. Water Temperature 86°F (30°C)
- Max. Inlet Pressure: 230 psi (15.9 Bar)
- Power Supply 9V DC
- (4) AA Batteries
- Connection Sizes: 3/4", 1", 1-1/4" NPT

### Materials

- Body: Brass ≤ .25% lead
- Internal Components: Brass ≤ .25% lead
- Acetal
- Nylon
- Seals: EPDM

### Approvals



### Application

The Taco FloodBreaker® is a whole house adjustable leak detection system that monitors several aspects of water usage. It shuts off the water supply once any of the monitored settings are reached. Use FloodBreaker to protect homes from water damage, eliminate waste and protect unoccupied or vacation properties. Not only can it protect against a large catastrophic leak but is capable of protecting against the small unnoticed leak that could go on for weeks, months or even indefinitely.

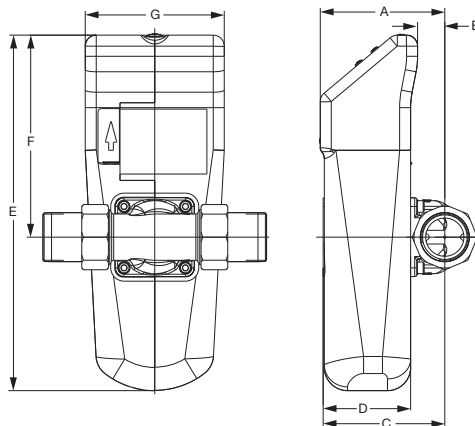
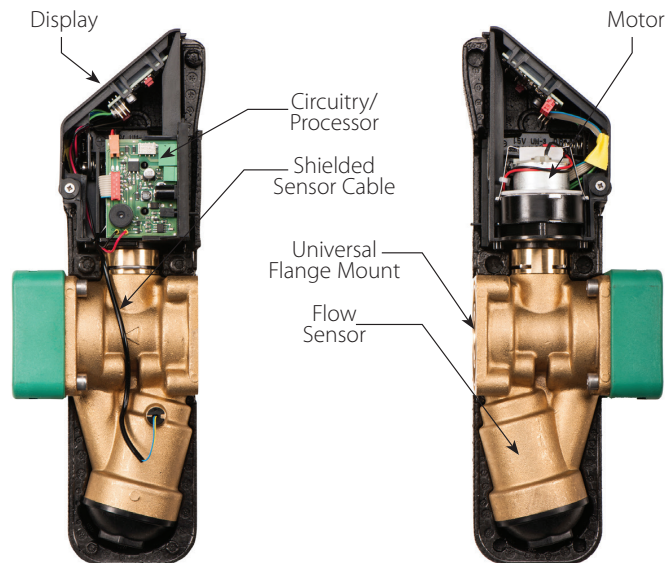

### FloodBreaker® Dimensions

DIMENSIONS (For reference only)	In.	mm
A	4-1/4	108
B	15/16	24
C	4-1/8	105
D	3	76
E	12-3/32	307
F	6-55/64	174
G	4-47/64	120

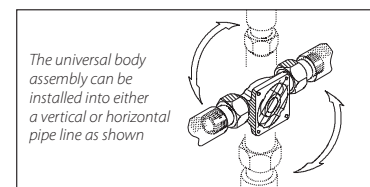

Taco, Inc., 1160 Cranston Street, Cranston, RI 02920 | Tel: (401) 942-8000 | FAX: (401) 942-2360

Taco (Canada), Ltd., 8450 Lawson Road, Suite #3, Milton, Ontario L9T 0J8 | Tel: (905) 564-9422 | FAX: (905) 564-9436

Visit our web site: www.TacoComfort.com | Printed in USA | ©2015 Taco, Inc.

