

### VorTech® & 4900 Series Air Separators

Taco's family of air elimination products delivers the most complete and effective means of air removal on the market. The ultimate micro bubble separation of the 4900 Series Air Separator or the enhanced level of the VorTech® Air Separator eliminates the damaging effects and irritating noise caused by unwanted system air. Available in 3/4" – 2" sizes, they require no minimum run of pipe and have a convenient 1/2" tapping for easy installation of an expansion tank.



# 4900 SERIES AIR SEPARATOR



## Application

The Taco 4900 Series Air Separators are designed for the complete elimination of air from closed loop heating and cooling systems up to a maximum temperature of 240°F and a maximum pressure of 150 psi. The principle on which the Taco 4900 Series Air Separator is based is a patented and proven method of removing gases from water: the PALL ring process.

## The PALL Ring Process Removes Air:

- Present Before or During the Filling of the System
- That Collects after the System is Filled
- Present in System Water in the Form of Small Bubbles and Micro-bubbles Entrained in the Water
- Dissolved in the System Water

## The Presence of Air can Lead to:

- Irritating Noises
- Reduced Efficiency
- Reduced Operational Life of the System as a Result of Internal Corrosion of Essential Parts such as the Boiler and Radiators
- Cavitation Erosion of the Pump Impeller
- Degraded Operation of the Circulation Pump

## The Coalescence Effect

Both small air bubbles and micro-bubbles will adhere to a surface and join together to form larger air bubbles. These combined bubbles then traverse up through the water and into the air chamber to be released by the vent.

## Pall Rings

An optimum coalescence effect is achieved by the 4900 Series' use of the patented pall ring process. The PALL Ring chamber is engineered to optimize the collision of the flowing system water with the PALL Rings. As a result of this collision, all of the gas containing water particles are brought into contact with the entire pall ring surface area. Even the smallest micro-bubble present in the water will adhere to the surface of a pall ring, allowing coalescence to occur and air to be removed.

## Conical Venting Chamber

The air chamber of the 4900 Series is conical in shape. The advantage of this construction is that the distance between the water level and the venting valve is greater than that of a straight air chamber, due to the effects of pressure. Thus any dirt or impurities floating on the fluid within the air separator will remain well clear of the venting mechanism during normal operating conditions. This means that fouling of the gearing and venting valve is reduced to a minimum.

## Features

- Patented PALL Ring Design
- Eliminates Air Induced System Noise
- Minimal Pressure Loss
- Vent can be Closed
- Large Surface Contact Area
- Protective Vent Plate
- Rugged Dependability
- Maximum Air Removal
- Convenient Expansion Tank Connection Tapping
- No Minimum Run of Pipe Requirement
- Bidirectional Flow

## Air Removal Diagram

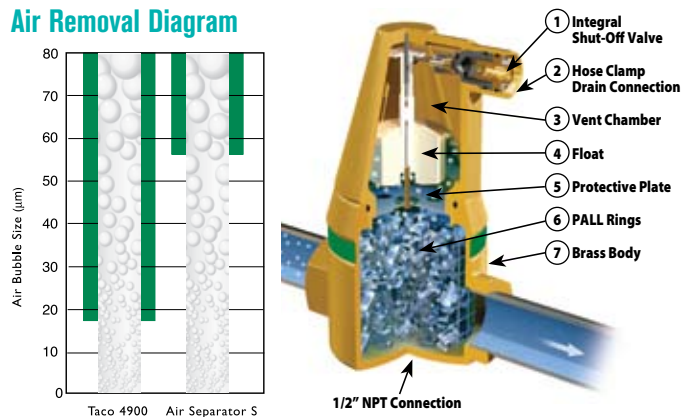

## 4900 Air Separators Were Proved to be Better!

Tests carried out at the Delft Technical University have unequivocally proved that 4900 Air Separators remove all micro-bubbles from 15 microns and up. This is three times better than comparable Air Separators!

## Pall Rings

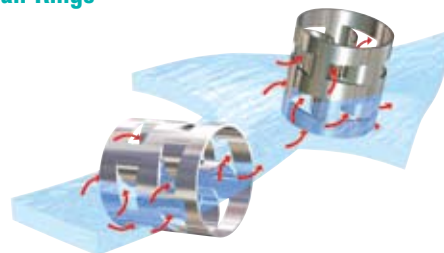

## Water Level Diagram

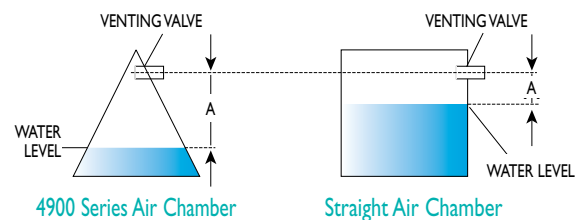

# VORTECH® AIR SEPARATOR



## Application

The Taco VorTech® Air Separator is designed to provide an enhanced level of air removal in hydronic heating, cooling or combinational systems. Air is quickly and effectively separated and vented through a factory installed Taco 3/4" Hy-Vent® up to a maximum pressure of 150 psi and a maximum temperature of 240°.

## Operation

The VorTech® Air Separator features a primary separation chamber where the process of air elimination is controlled and optimized. The specially designed tangential primary chamber creates a swirling effect, or "vortex," similar to a tornado. This swirling effect forms a low-pressure area in the center of the chamber. Air is drawn toward this lower pressure, and then once there it moves freely upward and out through the Taco 3/4" Hy-Vent®. Combined with the Bubble Breaker Cartridge and a downward direction change in the flow of water before exiting, air is quickly and effectively removed from the system.

## Features

- Unique Water Flow Pattern
- Works Efficiently with both Low Velocity Water and High Velocity Water
- 100% Factory Tested
- Unique Bubble Breaker Cartridge
- Replaceable High Capacity Hy-Vent®
- Enhanced Air Removal
- Convenient Expansion Tank Connection Tapping
- No Minimum Run of Pipe Required
- Vent can be Closed
- Eliminates Air Induced System Noise

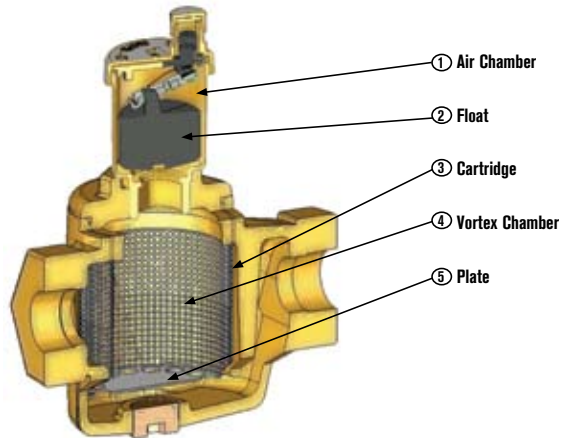

## Typical Installation of VorTech or 4900 Series

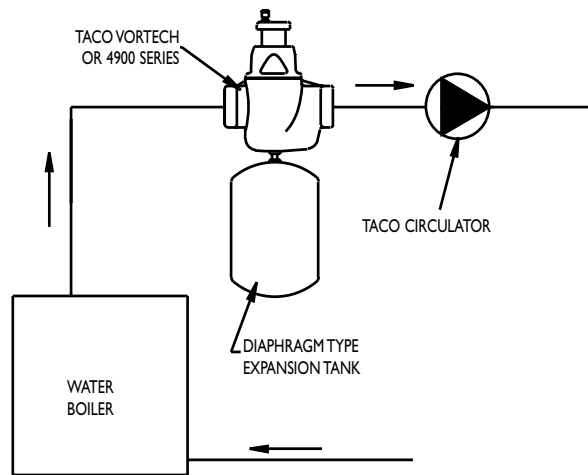

# Submittal Data Information VorTech® & 4900 Series Air Separators

Submittal Data # 101-040  
Supersedes: 03/03/08

Effective: 08/26/08

## 4900 Materials of Construction

Housing: Brass  
PALL Rings: Stainless Steel  
Venting Unit Components: Stainless Steel, EPDM, Viton, Brass, and Engineered Plastics

## 4900 Ratings

Maximum Operating Pressure: 150 psi  
Maximum Operating Temperature: 240°F  
Minimum Operating Temperature: 25°F  
Media: Water or Water/Glycol  
Maximum Velocity: 5 feet/sec

Product	Cv	Kv
49-075	14	12
49-100	24	20
49-125	37	32
49-150	49	42

## 4900 Dimensions & Weights Nominal Dim: inches (mm)

Model	Conn. Size	A	B	C (NPT)	C (SWT)	Wrench Flat Width	Approx. Shipping Weights	
							Lbs.	Kg.
49-075	3/4"	4-3/4 (121)	5-15/16 (151)	3-3/4 (96)	4-3/16 (107)	1-1/2 (38)	3.5	1.6
49-100	1"	5-1/2 (139)	6-3/4 (171)	4-3/8 (111)	4-13/16 (122)	1-3/4 (44)	4.5	2
49-125	1-1/4"	6-1/16 (154)	7-9/16 (192)	4-1/2 (114)	5-3/16 (132)	2-1/4 (57)	5.3	2.4
49-150	1-1/2"	6-1/16 (154)	7-9/16 (192)	4-1/2 (114)	5-7/16 (138)	2-1/2 (64)	5.4	2.5

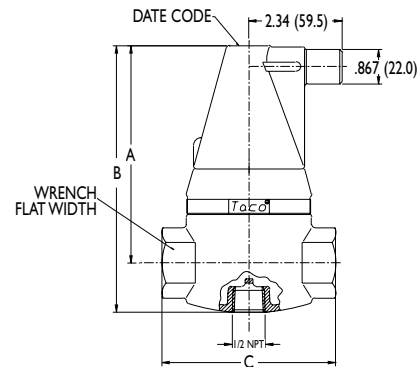

## VorTech® Materials of Construction

Body & Cap: Cast Iron  
Cartridge & Plate: Stainless Steel  
O-Ring: Viton  
Vent: Taco 419 Hy-Vent®

## VorTech® Ratings

Maximum Operating Pressure: 150 psi  
Maximum Operating Temperature: 240°F  
Media: Water or Water/Glycol  
Recommended Velocity: 4 feet/sec  
Maximum Velocity: 8 feet/sec

Product	Cv	Kv
VRTX075	14	12.5
VRTX100	15.5	14.1
VRTX125	21.4	17.0
VRTX150	34.8	30.1
VRTX200	42.7	36.9

## VorTech® Dimensions & Weights Nominal Dim: inches (mm)

Model	Conn. Size	A	B	C	D	E	Approx. Shipping Weights	
							Lbs.	Kg.
VRTX075	3/4" NPT	5 (127)	7 5/8 (194)	5 3/4 (146)	6 1/2 (165)	3 (76)	7	3.2
VRTX100	1" NPT	5 (127)	7 5/8 (194)	5 3/4 (146)	6 1/2 (165)	3 (76)	7	3.2
VRTX125	1 1/4" NPT	5 (127)	7 5/8 (194)	5 3/4 (146)	6 1/2 (165)	3 (76)	7	3.2
VRTX150	1 1/2" NPT	5 3/4 (146)	9 1/8 (232)	8 1/4 (210)	7 1/4 (184)	4 7/8 (124)	15	6.8
VRTX200	2" NPT	5 3/4 (146)	9 1/8 (232)	8 1/4 (210)	7 1/4 (184)	4 7/8 (124)	15	6.8

