



Submittal Data Information "BTL" Buffer Tanks

401-086

SUPERSEDES: New

EFFECTIVE: March 1, 2009

Job: _____

| ITEM | LOCATION | MODEL | QUANTITY | GALLONS |
|------|----------|-------|----------|---------|
|------|----------|-------|----------|---------|

SPECIFICATIONS

- Designed and constructed per ASME Code Section VIII, Division 1.
- Construction: Carbon Steel with exterior red oxide primer finish
- Maximum Design Pressure and Temperature: 125 psi @ 375°F
- Flanged inlet and outlet System Connections (standard sizes shown)
- Registered with the National Board of Pressure Vessel Manufacturers

OPTIONS (Consult Factory)

- Optional materials of construction
- Higher design pressures and temperatures
- Optional System Connection sizes available
- Grooved-end pipe System Connections
- Thermal insulation

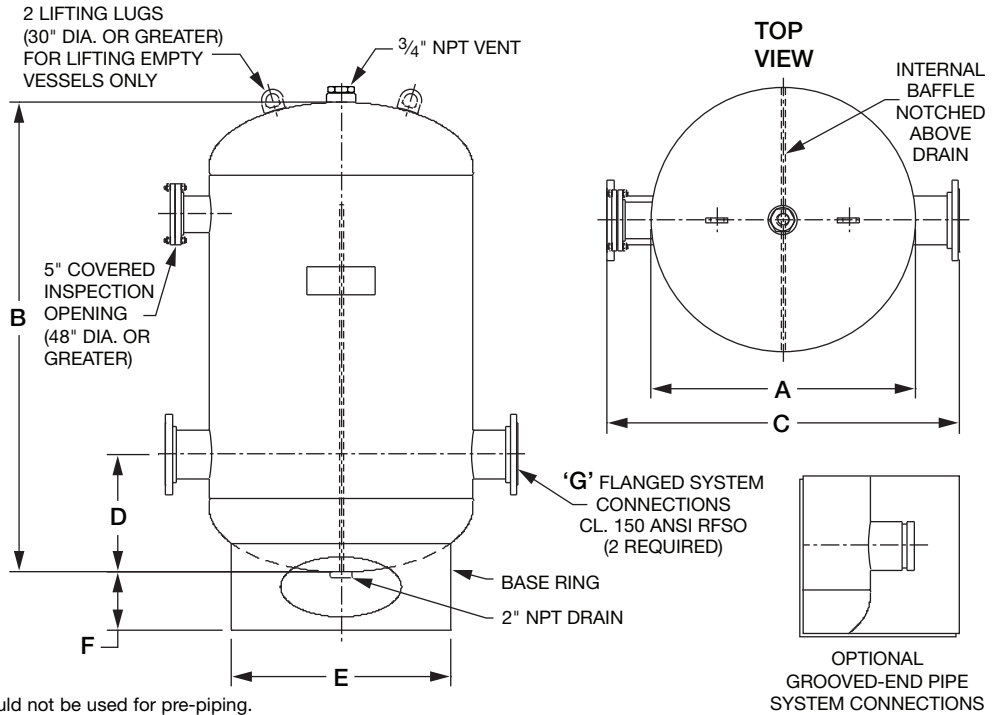

SIZES & DIMENSIONS

All dimensions shown are subject to change and should not be used for pre-piping. Contact your local Taco representative should certified dimensional drawings be required.

| MODEL NUMBER | TANK VOLUME | A | B | C | D | E | F | G | APPROX. WEIGHT |
|-----------------|-------------|---------------|------|--------------------------------|--------------------------------|---------------|-------------------------------|------|----------------|
| | GAL. | DIAMETER INCH | INCH | INCH | INCH | DIAMETER INCH | INCH | SIZE | |
| BTL0050F03-125N | 50 | 20 | 43 | 26 ³ / ₄ | 11 ¹ / ₂ | 16 | 6 ³ / ₄ | 3" | 180 |
| BTL0075F03-125N | 75 | 24 | 46 | 30 ³ / ₄ | 12 ⁵ / ₈ | 20 | 6 ³ / ₄ | 3" | 230 |
| BTL0100F03-125N | 100 | 24 | 61 | 30 ³ / ₄ | 12 ⁵ / ₈ | 20 | 6 ³ / ₄ | 3" | 270 |
| BTL0125F03-125N | 125 | 24 | 76 | 30 ³ / ₄ | 12 ⁵ / ₈ | 20 | 6 ³ / ₄ | 3" | 320 |
| BTL0150F03-125N | 150 | 30 | 60 | 36 ³ / ₄ | 14 ¹ / ₄ | 24 | 8 | 3" | 500 |
| BTL0180F03-125N | 180 | 30 | 71 | 36 ³ / ₄ | 14 ¹ / ₄ | 24 | 8 | 3" | 580 |
| BTL0200F03-125N | 200 | 30 | 78 | 36 ³ / ₄ | 14 ¹ / ₄ | 24 | 8 | 3" | 620 |
| BTL0250F04-125N | 250 | 36 | 69 | 45 ¹ / ₄ | 16 ¹ / ₄ | 30 | 7 ⁷ / ₈ | 4" | 690 |
| BTL0300F04-125N | 300 | 36 | 82 | 45 ¹ / ₄ | 16 ¹ / ₄ | 30 | 7 ⁷ / ₈ | 4" | 800 |
| BTL0350F04-125N | 350 | 36 | 94 | 45 ¹ / ₄ | 16 ¹ / ₄ | 30 | 7 ⁷ / ₈ | 4" | 890 |
| BTL0400F06-125N | 400 | 48 | 65 | 57 ¹ / ₄ | 16 ⁵ / ₈ | 40 | 8 ⁵ / ₈ | 6" | 980 |
| BTL0450F06-125N | 450 | 48 | 72 | 57 ¹ / ₄ | 16 ⁵ / ₈ | 40 | 8 ⁵ / ₈ | 6" | 1050 |
| BTL0500F06-125N | 500 | 48 | 79 | 57 ¹ / ₄ | 16 ⁵ / ₈ | 40 | 8 ⁵ / ₈ | 6" | 1130 |
| BTL0700F06-125N | 700 | 48 | 100 | 57 ¹ / ₄ | 16 ⁵ / ₈ | 40 | 8 ⁵ / ₈ | 6" | 1270 |
| BTL0850F06-125N | 850 | 54 | 99 | 63 ¹ / ₄ | 22 ⁵ / ₈ | 44 | 9 ⁹ / ₈ | 6" | 1850 |
| BTL1050F08-125N | 1050 | 60 | 99 | 69 ³ / ₄ | 24 ³ / ₄ | 50 | 9 ³ / ₄ | 8" | 2100 |

COMMENTS: _____

Do it Once. Do it Right.®

TACO, INC., 1160 Cranston Street, Cranston, RI 02920 Telephone: (401) 942-8000 FAX: (401) 942-2360.
TACO (Canada), Ltd., 8450 Lawson Road, Unit #3, Milton, Ontario L9T 0J8. Telephone: 905/564-9422. FAX: 905/564-9436.

Visit our web site at: <http://www.taco-hvac.com>

Printed in USA
Copyright 2009
TACO, Inc.